

NOTES

1. Material: A-286 Alloy, NAS1351N4-XX SHC Screw
2.  Reduce head diameter and add chamfer as shown.
3. De-burr and break sharp edges.
4. Surface Finish: None.
5. Cleanliness: Part must be delivered COMPLETELY free of all grease, oil and grit.

REVISIONS				
Rev	Change Description	Date	By	Chk
-	Initial Revision	21-Oct-13	RH	RW

Dash	Length
6	0.375
8	0.500
10	0.625
12	0.750
14	0.875
16	1.000
20	1.250
24	1.500
28	1.750
32	2.000
36	2.250

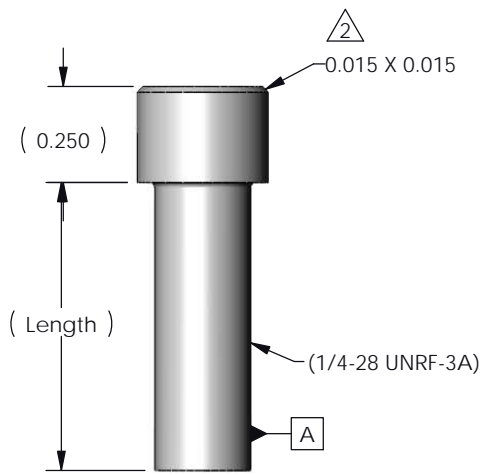
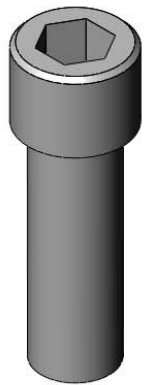
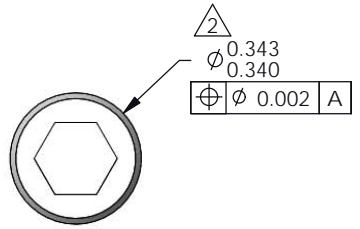

PLANETARY SYSTEMS CORPORATION
 2303 Kansas Avenue, Silver Spring, MD 20910, (301) 495-0737 PROPRIETARY AND CONFIDENTIAL

THE INFORMATION CONTAINED IN THIS DRAWING, OR ANY REPRODUCTION THEREOF, IS PROPRIETARY INFORMATION AND THE PROPERTY OF PSC. IT SHALL NOT BE DISCLOSED, COPIED, DUPLICATED, OR USED FOR MANUFACTURE, PRODUCTION, OR PROCUREMENT, WITHOUT THE EXPRESS WRITTEN PERMISSION OF PSC.

ALL DIMENSIONS ARE IN INCHES

TOLERANCES:
 x.xxxx +/- 0.001
 x.xxx +/- 0.005
 x.xx +/- 0.010
 x.x +/- 0.030
 x +/- 0.2

 32/

ORIGINAL DESIGN	RH	21-Oct-13	TITLE	Reduced Head 0.25-28 SHC Screw	
Material: see Note 1			SIZE	NUMBER	REV
DO NOT SCALE FROM DRAWING			A	4000845-X	-
SCALE 2:1		CAGE CODE: 1PHA7		SHEET 1 OF 1	